



Seekur Jr

Seekur Jr is an all-terrain four wheel skid-steer robot ideal for laboratory experimentation or outdoor operation in any weather. Seekur Jr can easily be outfitted with large payloads including sensor packages, robotic arms, or your own custom accessories. The robot comes complete with one battery and charger, segmented bumper array, emergency stop switches, joystick, and a microcontroller with SeekurOS firmware, as well as Pioneer SDK advanced mobile robotics development software.

Adept MobileRobots research robots are the world's most popular intelligent mobile platforms for education and research. Their versatility, reliability, and durability have made them the preferred platform for advanced intelligent robotics. All research platforms are pre-assembled, customizable, and upgradeable, and will last through years of continued use.

Specifications	
Construction	Body: Powder-coated aluminum IP Rating: IP-54 Tires: 16 inch Pneumatic
Operation	Robot Weight: 77 kg Operating Payload: 40 kg Temperature Rating: -5° to 35° C
Skid Steering Drive	Turn Radius: 0 cm Swing Radius: 52 cm Max. Forward/Backward Speed: 1.2 m/s Max. Traversable Step: 12 cm Max. Traversable Grade: 75% Traversable Terrain: Indoor use: tile and flooring (may damage carpet) Outdoor use: pavement, grass, snow, rocky terrain, and sand All-weather capable
Power	Run Time: 3-5 hours (with no accessories) Charge Time: 3 hours Software-Switchable Power Supplies: 5 V @ 2 A regulated 12 V @ 2 A regulated 24 V @ 1 A regulated 20 A Unregulated Battery Power (24 V Nominal)
Batteries	Supports up to 3 at a time Capacity: 10 Ah (each) Chemistry: NiMH <i>Note: Batteries are accessible through latched access panel for hot-swapping (continuous operation)</i>
Microcontroller:	Phytec MPC-565

Product Features and Benefits

- **Reliable** - Construction is durable and rugged. Seekur's powerful motors can climb through rough terrain and its sealed aluminum body protects against severe weather. Easily handles the gaps, bumping, jarring, and other obstacles that hinder other robotic platforms.
- **Easy to Use** - Comes fully assembled and integrated with its accessory packages.
- **Customizable** - Includes mounting plates with tapped holes and readily accessible user I/O and power ports for custom sensors and effectors. Easily accessorize by choosing from many supported and tested accessories that integrate with your robotic platform.
- **Technical Support** - Pioneer software and hardware come fully documented with additional help available through our product support team.

Seekur Jr

Dimensions (mm)

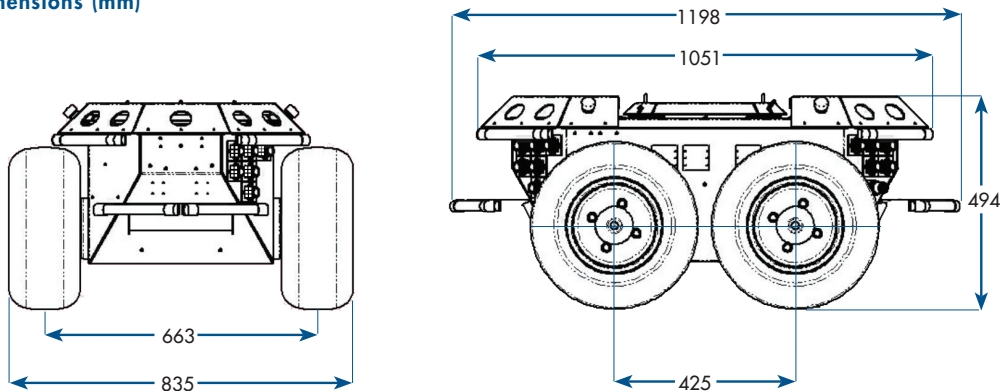

Core Software - included with all research platforms

ARIA provides a framework for controlling and receiving data from all MobileRobots platforms, as well as most accessories. Includes open source infrastructures and utilities useful for writing robot control software, support for network sockets, and an extensible framework for client-server network programming.

MobileSim open-source simulator which includes all MobileRobots platforms and many accessories.

MobileEyes graphical user interface client for remote operation and monitoring of the robot.

Mapper 3-Basic tool for creating and editing map files for use with ARIA, MobileSim, and navigation software.

Accessory Support Software - bundled with purchase of robotic accessory

ARNL enables robust, laser-based autonomous localization and navigation.

MOGS fuses robot and DGPS sensor data to guide your mobile robot outdoors.

Robotic Arm Support Pioneer arms are packaged with integrated software support.

Speech Recognition and Synthesis Library: Easy-to-use C++ development library for speech recognition based on the open source Sphinx2 system. Speech synthesis (text-to-speech) based on Cepstral synthesizer.

ACTS Color Tracking System: Software application to read images from a camera and track the position and sizes of multiple color regions. Information can be incorporated into your own software via ARIA.

Optional Industrial-Grade Internally-Mounted Computers (can support up to 2)

Mamba EBX-37 (Dual Core 2.26 GHz - 2-8 GB RAM)

6 X USB2.0 Ports

2 X PC/104+ Slots

4 X RS-232 Serial Ports

2 X 10/100/1000 Ethernet Ports

Onboard Audio & Video

Solid State Drive

Optional Wireless Ethernet

Optional Accessories:

- Laser-range finders
- Mono- and stereo-vision cameras
- WiFi wireless Ethernet
- Robotic arms
- Speakers and microphones
- Joystick
- GPS & DGPS
- 6 DOF Inertial Measurement Unit
- Wireless 900MHz radio
- Many more...

Include our integrated & supported accessories with your Seekur Jr.

Here are some popular configurations to choose from:



Outdoor Navigation



Manipulation



Vision and Mapping

More Information:

See our website www.mobilerobots.com for a full range of supported accessories or contact our sales department to discuss your application.



Adept MobileRobots, LLC. 10 Columbia Drive, Amherst, NH 03031

Tel: 603-881-7960 Email: sales@mobilerobots.com

www.mobilerobots.com

Specifications subject to change without notice.

©2011 Adept Technology, Inc. ALL RIGHTS RESERVED. The information provided in this communication or document is the property of Adept Technology, Inc. and is protected by copyright and other intellectual property laws. In addition, any references to any Adept Technology, Inc. products are the marks and property of Adept Technology, Inc. [and may be registered trademarks]. All other trademarks or tradenames are the property of their respective holders.